

Leakage Rates through Geomembrane Liners beneath Phosphogypsum Disposal Facilities

J. E. Garlanger, N. F. Fuleihan & A. H. Riad
Ardaman & Associates Inc, Orlando, FA, USA

ABSTRACT: This paper presents a methodology for predicting the quantity of leakage through a defect in a geomembrane bottom liner beneath a phosphogypsum disposal facility. The theoretical basis for the prediction methodology is introduced and then laboratory verification tests are presented and evaluated. The results indicate that fine gypsum particles can readily enter and plug defects in the underlying geomembrane liner, causing a reduction in the leakage rate through any missed defects. Upper bound leakage predictions, assuming that gypsum does not plug the defect, overestimate the leakage rate by a factor of 2 to 6. Best estimate predictions, assuming gypsum plugs the defect, are approximately the same as or only slightly higher than measured leakage rates. Results of the analytical and laboratory work presented in this paper assisted the Florida Department of Environmental Protection to enact minimum liner design standards for phosphogypsum disposal facilities that are at the same time economically viable and adequately protective of groundwater resources.

1. INTRODUCTION

Phosphogypsum is a fertilizer industry by-product resulting from the manufacturing of phosphoric acid from phosphate rock. Approximately 150 million tons of phosphogypsum are generated worldwide each year, with about 33% produced in the United States (Ghafoori and Chang, 1993). Most of the phosphogypsum is disposed of in above ground ponded disposal facilities commonly referred to as "gypsum stacks". The impoundments are raised using the upstream method of dam construction (Vick, 1983). Gypsum stacks with base areas of up to 250 hectares and heights of over 70 meters are not uncommon. The process water used to slurry and transport gypsum to the disposal facilities has a pH of approximately 2 and contains dissolved metals at concentrations greater than the USEPA drinking water standards.

There has been a growing concern about the potential impact of phosphogypsum management facilities on groundwater resources. For the past three years, the authors' firm has been working with the Florida Department of Environmental Protection (FDEP) to develop minimum design criteria for gypsum stack liners that will be both adequately protective of groundwater and reasonably cost effective. The phosphogypsum

management rule that Florida recently adopted requires that, as a minimum, all new phosphogypsum stacks be constructed on a 1.5 mm HDPE liner directly overlain by a 0.6-meter thick layer of compacted gypsum (FDEP, 1993). A typical cross section of a gypsum stack constructed on a geomembrane is presented in Figure 1.

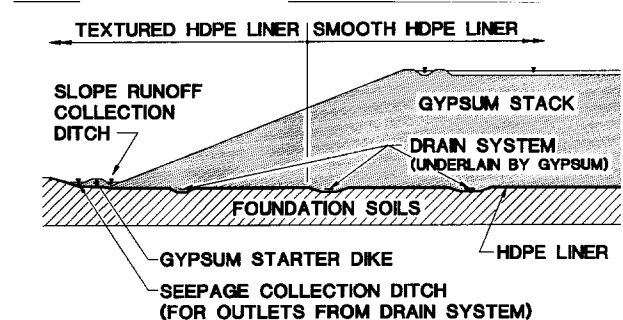

Fig. 1 Cross section of gypsum stack on geomembrane

2. PREDICTIVE METHODOLOGY

Geomembranes are essentially impervious to liquid flow. However, pinholes, seam or joint imperfections, tears and other defects are generally assumed to be present in a geomembrane installation even when a thorough quality control plan is implemented to minimize the presence of such defects. Direct

permeation through a geomembrane liner is negligible compared to the leakage through a missed defect. Therefore, only leakage through defects will be addressed in this paper. Figure 2 illustrates the seepage conditions in the vicinity of a hole in a geomembrane underlying a gypsum stack.

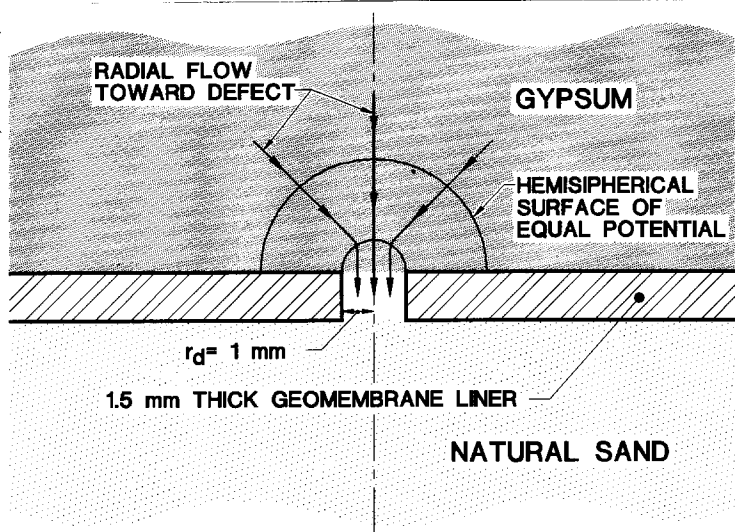

Fig. 2 Flow through defect in geomembrane

The quantity of seepage through a hole in a geomembrane is a function of the size and shape of the hole, the permeability of the gypsum surrounding and filling the hole, and the head difference across the liner.

2.1 Gypsum Properties

In contrast to many other waste products (e.g., municipal solid waste), gypsum is characterized by a moderately low hydraulic conductivity. Phosphogypsum is transported to a gypsum stack as a slurry having a solids content typically in the range of 10 to 15 percent. Upon contact with the quiescent water in the gypsum pond, the silt-sized gypsum particles settle and form a sedimentary deposit across the bottom of the pond. As more sediment forms, the density of the buried gypsum increases as a result of self-weight consolidation and secondary compression. If the bottom of the gypsum stack were lined with a geomembrane, the sedimented gypsum would be in full, intimate contact with the geomembrane. Any defects in the geomembrane would therefore be in contact with the gypsum and, if the size of the defect is larger than the size of a gypsum particle (i.e., if the radius of the hole in the geomembrane, r_d , is greater than 0.05 mm), gypsum will be forced into the defect by the flowing water. The resulting seepage forces will consolidate the gypsum surrounding and filling the defect to a density greater than that of the adjacent gypsum.

Depending on the effective stress (height of stack) or in situ density, and on crystal morphology, the hydraulic conductivity of gypsum can range over three orders of

magnitude. Figure 3 presents the hydraulic conductivity measured on undisturbed samples of gypsum from five different stacks as a function of void ratio and stack height.

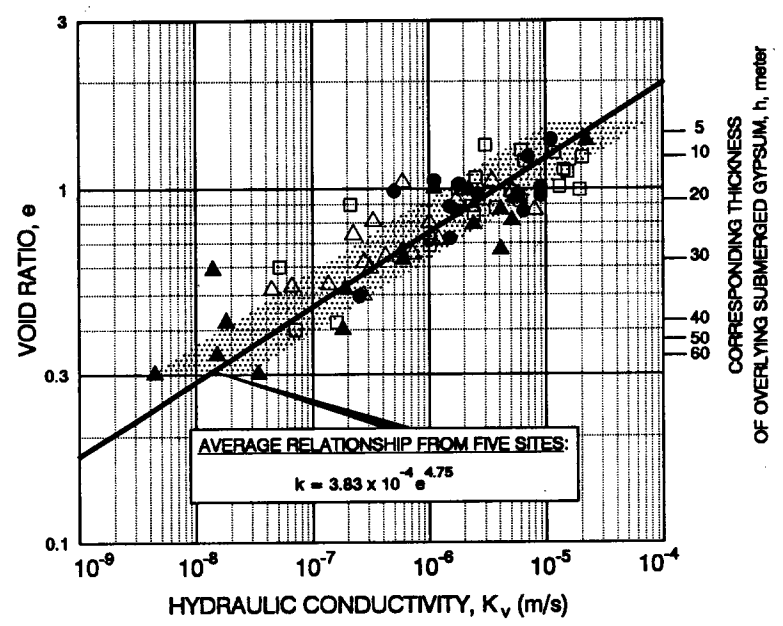

Fig. 3 Hydraulic conductivity of gypsum as a function of void ratio and stack height

As the stack height increases, the gypsum density increases (and the void ratio decreases), resulting in a corresponding reduction in hydraulic conductivity. As shown on Figure 3, the hydraulic conductivity of gypsum decreases from about 10^{-5} m/s at shallow depths to 10^{-8} m/s at depths in excess of 50 to 60 meters.

2.2 Size and Frequency of Liner Defects

Even though an extensive third party quality assurance/quality control program is required by FDEP during installation of a geomembrane liner for all solid waste disposal facilities in Florida, the leakage evaluations described herein conservatively assumed a frequency of 5 missed defects per hectare, each consisting of a circular hole with a diameter ranging from 1 to 2 mm. This is double the number of defects observed and recommended by Giroud and Bonaparte (1989).

2.3 Predictive Theoretical Model

The following assumptions were made in developing the predictive model: (i) Darcy's law applies; (ii) gypsum particles enter the defect and consolidate under the weight of the overlying gypsum and seepage forces associated with water flowing toward and through the defect; (iii) soil underlying the geomembrane is a pervious filter for the gypsum; (iv) gypsum above the liner is in full, intimate contact with the geomembrane;

(v) the defect consists of a circular hole; and (vi) continuity of flow and conservation of energy govern the leakage process. Based on the above assumptions, the following equation was developed for use in predicting the leakage rate through a defect in a geomembrane liner (Wissa and Fuleihan, 1993).

$$Q = \frac{4 k_m r_d h}{1 + \frac{4 t k_m}{\pi r_d k_v}} \dots\dots\dots (1)$$

Where "Q" is the leakage rate through the hole; "k_m" is the effective coefficient of permeability of the gypsum immediately above the liner (which for an anisotropic ratio of 2 is equal to √ 2 times the vertical coefficient of permeability); "k_v" is the vertical coefficient of permeability of gypsum in the hole; "h" is the hydraulic head across the liner; "r_d" is the radius of the hole; and "t" is the thickness of the geomembrane.

If the head loss through the defect were to be discounted, i.e., if one were to assume that the gypsum will not plug the missed defect, the denominator in Equation 1 would be reduced to unity and the following equation will then govern flow through the defect.

$$Q = 4 k_m r_d h \dots\dots\dots (2)$$

Note that Equation 2 represents the flow through a flush bottom well at an impervious boundary. This equation was originally derived by Forchheimer (1930).

2.3 Predicted leakage through a 2-mm diameter defect

The leakage rate through a 2-mm diameter defect in a 1.5-mm thick HDPE liner underlying a gypsum disposal facility can be calculated from Equation 1 or 2 for differing stack heights, assuming the hydraulic head across the liner is equal to the stack height. The hydraulic conductivity above and within the defect was determined based on the relationship with void ratio shown in Figure 3. The void ratio above and within the defect was determined using a relationship between density and effective stress developed from measurements of pore water pressure and *in situ* densities on 37 undisturbed samples retrieved at varying depths from 3 different gypsum stacks. The upper bound (no gypsum in defect) and best estimate (gypsum in defect) predicted leakage rates are presented graphically in Figure 4.

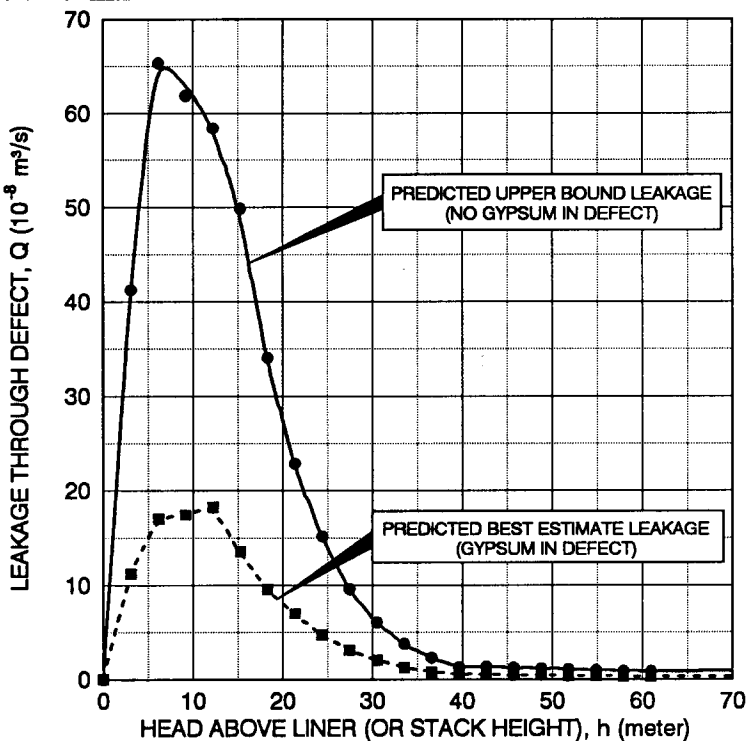

Fig. 4 Predicted leakage through a 2-mm diameter defect versus stack height

As shown, the leakage rate initially increases with increased stack height due to the increase in applied hydraulic head. At greater heights, however, the exponential reduction in the hydraulic conductivity of the gypsum above the liner results in a reduction in the leakage rate in spite of the continued linear increase in hydraulic head.

It should be mentioned that the leakage rates presented in Figure 4 neglect to consider the beneficial effect of other important design features in the liner system of a phosphogypsum stack. For example, the drain system constructed within gypsum above the geomembrane would cause a reduction in the average hydraulic head above the liner, and, hence, a reduction in the average leakage rate from the facility. This reduction is not accounted for in the graphs presented in Figure 4.

Because of the relatively low densities (higher void ratios) and correspondingly higher hydraulic conductivities at the lower stack heights, the predicted leakage rates are higher during the early life of the stack than at maturity. To reduce the predicted seepage rate during this early period in the life of the stack, the phosphogypsum management rule (FDEP, 1993) calls for placing a 0.6-meter thick compacted gypsum layer on top of the geomembrane. Compacted gypsum is required by the rule to have a hydraulic conductivity no greater than 10⁻⁶ m/s, i.e., equivalent to the hydraulic conductivity of sedimented gypsum at a stack height of approximately 25 meters. The resulting

liner system has been designated an inverted composite liner.

3. VERIFICATION OF THEORETICAL MODEL

A large scale field test was performed to: (i) demonstrate that gypsum can be successfully compacted on top of the geomembrane liner using conventional compaction equipment; and (ii) verify that there is an intimate contact between the compacted gypsum and the HDPE liner. The field test was observed by representatives of the eight Florida fertilizer companies, the FDEP, and their respective consultants. A photograph of the contact between the gypsum and geomembrane is presented in Figure 5.

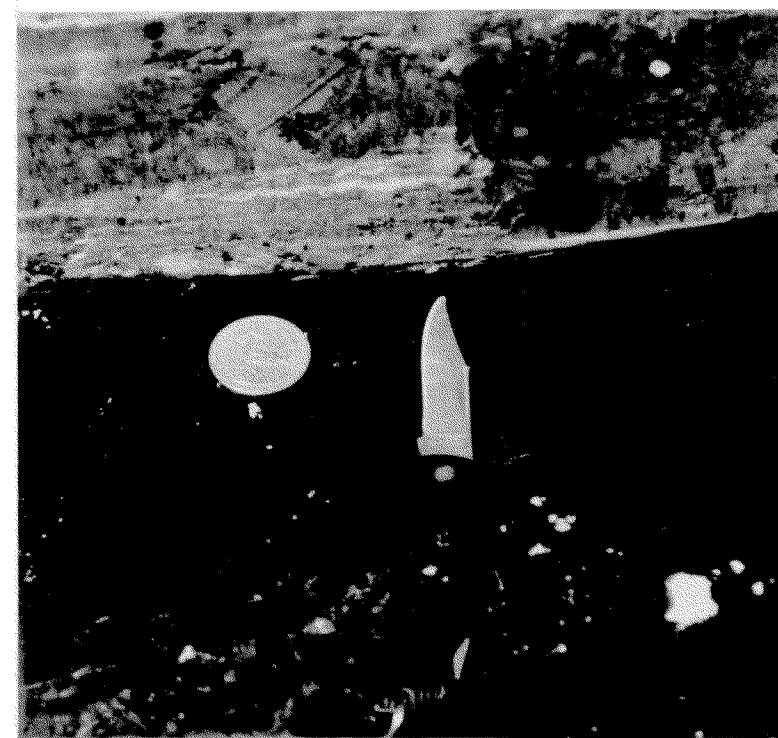

Fig. 5 Contact between compacted gypsum and liner

Two series of laboratory leakage tests were performed to verify the predictive methodology and the assumption of intimate contact. The first set was performed to simulate leakage through defects in a geomembrane liner overlain by sedimented gypsum. The second series was performed to measure leakage through defects in a liner overlain by a 0.45-meter layer of compacted gypsum.

3.1 Leakage through defects in liner overlain by simulated sedimented gypsum

To verify the leakage equations presented above, laboratory permeability tests were performed on two lightly remolded gypsum specimens in flexible membrane triaxial-type permeameters. The gypsum was placed and lightly rodded to a void ratio of about 1,

similar to void ratios typically measured after initial sedimentation. A piece of 1.5-mm thick geomembrane liner was placed beneath each of these gypsum specimens. A 1.0-mm diameter circular hole had been previously punched at the center of one of the two liners, and a 2.0-mm diameter hole had been previously punched in the other.

Constant head permeability tests were conducted in the triaxial permeameters. The specimens were consolidated under isotropic effective consolidation stresses, increased gradually from 35 to 620 kPa, and permeated after each consolidation stage with gypsum-saturated water using net hydraulic heads ranging from 3.9 to 36 meters of water. Permeation was induced under backpressure to achieve saturation.

A similar permeability test was also performed on a gypsum specimen compacted to the same initial density and subjected to the same confining stresses, but without the liner, to measure the vertical hydraulic conductivity of the gypsum at the different consolidation stresses and hydraulic heads. An anisotropy ratio of 2 was then used to calculate the mean hydraulic conductivity above the defect in the geomembrane.

Results of the leakage rate tests are summarized in Figures 6 and 7. The leakage rates predicted by Equations 1 and 2 are also presented on both figures.

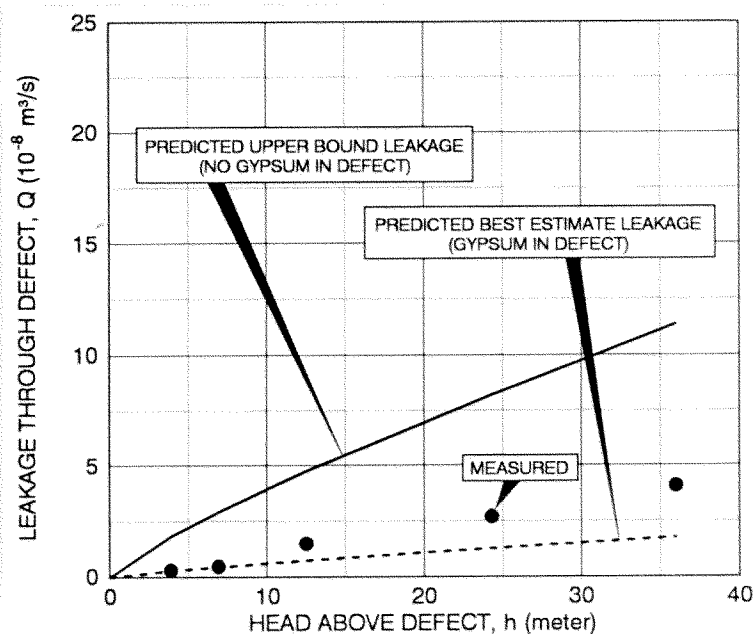

Fig. 6 Leakage rate through 1-mm defect in liner

As shown, the measured leakage rates through the 1-mm diameter hole lie closer to the best estimate theoretical curve, indicating that the defect was almost completely filled with gypsum. The measured rates through the 2-mm diameter hole were actually slightly lower than the best estimate predictions, documenting the presence of consolidated gypsum in the hole, and indicating that the gypsum in and/or above the defect

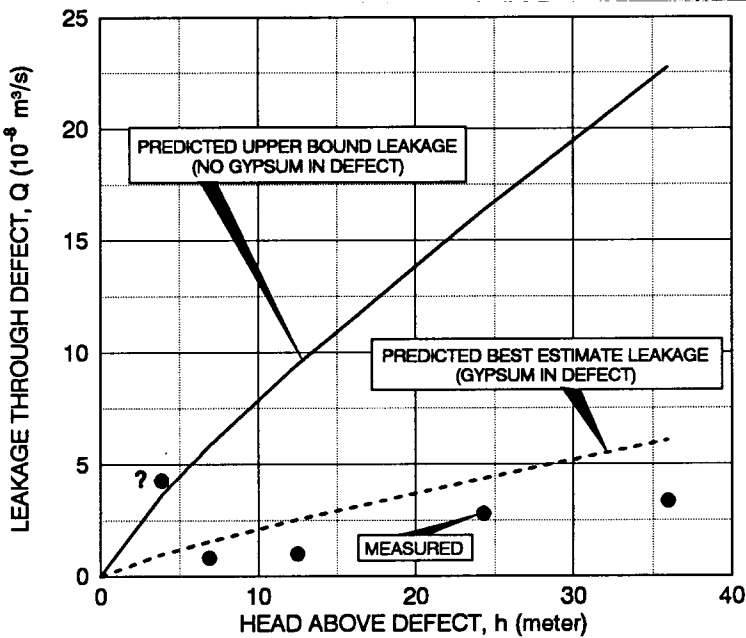

Fig. 7 Leakage rate through 2-mm defect in liner

had a lower hydraulic conductivity than measured in the control test specimen. The ratio of the upper bound predictions to the measured leakage rates for both defect sizes generally ranged from 2.8 to 9.7, with a gross average value on the order of 6. The ratio of the measured leakage rates to the best estimate predictions generally ranged from 0.4 to 2.3, with a gross average value on the order of 1.

3.2 Leakage through defects in liner overlain by a 0.45-meter thick layer of compacted gypsum

To determine the leakage through a defect in a 1.5-mm liner overlain by a 0.45-meter thick layer of compacted gypsum, a laboratory test was conducted in the specially fabricated apparatus shown in Figure 8. The gypsum in the laboratory apparatus was compacted in four equal lifts to an average void ratio of about 0.66, similar to that documented above the geomembrane in the previously referenced large-scale field test.

Two 1-mm diameter and two 2-mm diameter defects had been drilled through the 1.5-mm thick HDPE liner underlying the compacted gypsum shown on Figure 8. The outflow from each individual defect was monitored independently through a separate outlet tube placed beneath each of the four defects.

After compaction, gypsum saturated water was added to the cell and the top cover was bolted down. A hydraulic head of about 1.5 meters was applied and the outflow from each defect was measured. The applied head was then increased to about 3.5 meters and the measurements repeated. After completing all measurements, the apparatus was disassembled to examine the liner and to obtain samples for testing.

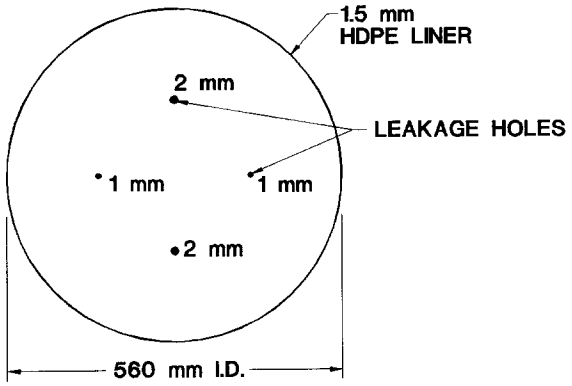
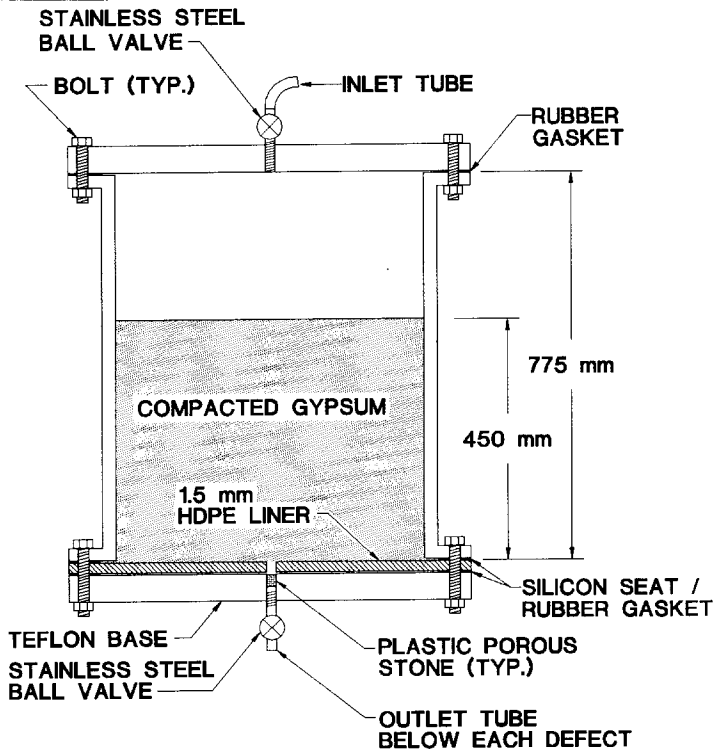

Fig. 8 Large scale leakage test apparatus

Permeability tests were performed on two 50-mm cubical specimens trimmed from the bottom of the compacted gypsum layer above the geomembrane. Each cube sample was tested in the vertical and horizontal directions as needed to document both the horizontal and vertical hydraulic conductivities, k_h and k_v , of the compacted gypsum layer. The average vertical hydraulic conductivity equalled 4.2×10^{-7} m/s and the anisotropy ratio, k_h/k_v , for the compacted gypsum was determined to be 1.1. (Note that sedimented gypsum usually exhibits a higher anisotropy ratio, on the order of 2.)

An examination of the defects in the geomembrane indicated that gypsum particles had completely filled the 2-mm diameter defects and had partially filled the 1-mm diameter defects. The measured and predicted leakage rates through the liner defects are presented in Figures 9 and 10.

As shown, the measured leakage rates were always lower than those predicted by the upper bound model. The ratio of the upper bound predictions to the measured

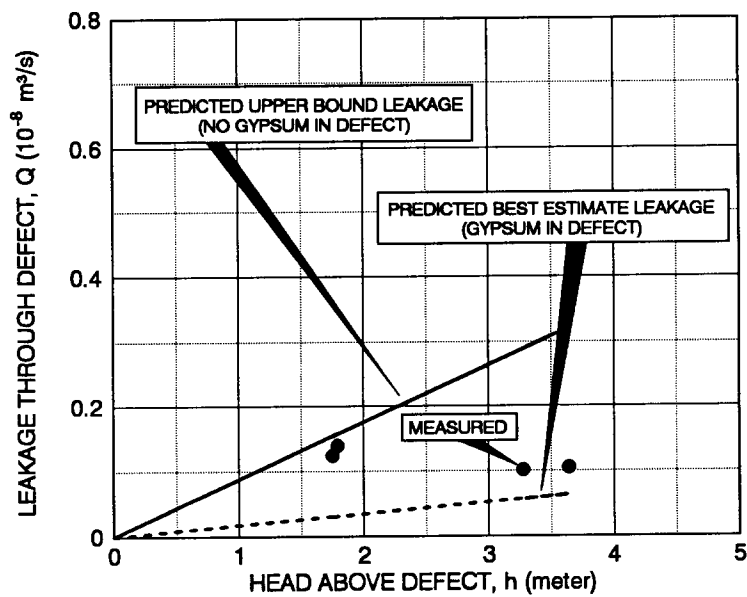

Fig. 9 Leakage rate through 1-mm defect in liner overlain by a layer of compacted gypsum

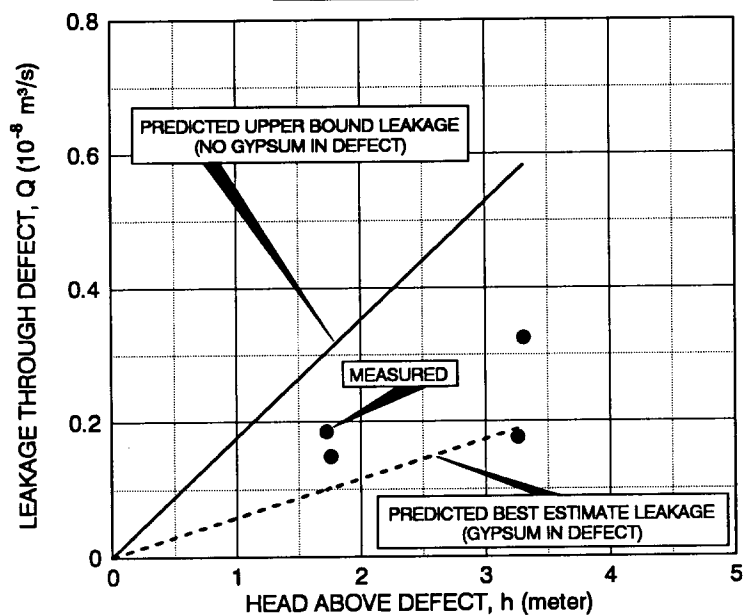

Fig. 10 Leakage rate through 2-mm defect in liner overlain by a layer of compacted gypsum.

leakage rates ranged from 1 to 3.3, with an average of 2.1 based on 8 measurements. The measured leakage was somewhat higher than predicted using the best estimate equation. The ratio of the measured leakage rates to the best estimate prediction ranged from 1 to 4.3, with an average value of 1.8. The results confirm the hypothesis that gypsum particles will at least partially fill any defects in the geomembrane liner even if compacted gypsum is used in lieu of sedimented gypsum. Note that at hydraulic heads greater than 3 meters, the actual leakage rates are expected to approach the best estimate predictions.

4. SUMMARY AND CONCLUSIONS

A methodology for predicting the leakage rate through liner defects beneath phosphogypsum stacks is presented. Laboratory verification of leakage rates support the validity of the predictive methodology. The following are the main conclusions pertaining to leakage through defects in a geomembrane liner when directly overlain by gypsum:

- Gypsum particles migrate into any missed liner defects causing a significant reduction in leakage rates through any such defects.
- The upper bound leakage model, which discounts the presence of gypsum in the defect, typically overpredicts the leakage rate by a factor of 2 to 6.
- The best estimate leakage model, which considers the presence of gypsum in the defect, provides a reasonable estimate of the leakage rates through liner defects when the geomembrane is overlain by sedimented gypsum. It also provides a realistic lower bound estimate for the case where the liner is overlain by compacted gypsum.

ACKNOWLEDGEMENTS

Financial support for the work presented herein was provided by the Florida Phosphate Council. The authors would also like to acknowledge the contribution of IMC Fertilizer, Inc. Dr. J.P. Giroud provided invaluable comments throughout this project.

REFERENCES

- Florida Department of Environmental Protection (1993). Phosphogypsum Management, Chapter 17-673, Florida Administrative Code.
- Forchheimer, P. (1930). *Hydraulick (Hydraulics)*, B. G. Teubner, Leipzig und Berlin, Germany.
- Ghafoori, N and Chang, W. F. (1993). Investigation of Phosphate Mining Waste For Construction Materials, *Journal of Materials in Civil Engineering*, ASCE, Vol. 5, No. 2, pp. 249-264.
- Giroud, J.P. and Bonaparte, R. (1989) Leakage through Liners Constructed with Geomembranes - Part I. *Geomembrane Liners, Geotextiles and Geomembranes*, Vol. 8, No. 1.
- Vick, Steven G. (1983). *Planning, Design, and Analysis of Tailings Dams*, John Wiley & Sons, New York.
- Wissa, A.E.Z. and Fuleihan, N.F. (1993). Design and Reclamation of Phosphogypsum Disposal Sites, *Proceedings of the AIChE Symposium on Advances in Phosphate Fertilizer Technology*, AIChE, N.Y.