

# Geogrid reinforced railway embankment on piles – Monitoring

E. Gartung & J. Verspohl

LGA Geotechnical Institute, Nürnberg, Germany

**ABSTRACT:** To cross an area of deep, soft, organic soil deposits in northern Germany, the embankment of a double track trunk railway line is founded on ductile cast iron piles and concrete pile caps. The embankment has a height of 2.5 m, it is reinforced by 3 layers of polyester geogrids. The performance of the reinforcement and of the piles is monitored by strain gauges, rod extensometers, acceleration transducers and conventional surveying. The first part of the geogrid reinforced embankment has been in service since more than 2 years. The measurements reveal the anticipated deformations and the satisfactory performance of the novel structure.

## 1 INTRODUCTION

The reunification of the eastern- and the western parts of Germany in 1990 created an increased traffic demand which could not be met by the existing road- and railroad network. So, extensive construction has been initiated to improve older facilities and to construct new additional transportation lines.

In the course of these activities, the 100 years old double track railway from Magdeburg to Berlin had to be partially reconstructed for train velocities of 160 kph. West of Berlin, the railway line traverses a landscape with beautiful lakes, which unfortunately are surrounded by deep deposits of soft organic soils. Here, the old railway tracks had suffered considerable settlements in the past, so it was necessary to improve the bearing capacity and deformational behavior of the ground in this area. Instead of the originally intended replacement of the soft peat to greater depth with more competent soils, the Railway Planning and Construction Company, PBDE (Planungsgesellschaft Bahnbau Deutsche Einheit), accepted the proposal of a contracting joint venture to construct a geogrid reinforced embankment on piles. The advantages of this new concept are:

1. Savings in construction time and money.
2. Convenient execution of the construction of half the embankment for one track, while trains run on the other half of the embankment.

3. Minimization of disturbance to the sensitive ecological environment.

Over a total length of 2100 meters, the geogrid reinforced structure was erected in 1994 to 1995. Trains have been passing over the first section of the new structure since May 1994. The construction was completed in December 1995. The performance of the structure has been monitored by two extensively instrumented sections and in addition by conventional surveying. The present paper reports on the monitoring system and on some typical measurement results.

## 2 STRUCTURAL SYSTEM

At the site, the ground consists predominantly of peat and soft, organic silt above medium dense sand which is encountered at varying depths between 5 and 30 meters. The undrained shear strength of the soft strata is as low as 6 to 8 kPa in the area adjacent to the railway embankment. However, below the embankment, the soil has experienced consolidation for about 100 years, and has achieved an undrained shear strength of generally at least 15 kPa. This was the specified minimum value required for the installation of the ductile cast iron piles, which are surrounded by cement grout, extruded from the pile tip during pile driving. The execution of construction was preceded by detailed ground explorations for the determination of the locally

required pile length and for the verification of the minimum shear strength of the soft soil. A site specific pile driving criterion was established on the basis of several pile loading tests.

The structural system is shown on fig. 1. It consists of the geogrid reinforced embankment, the precast concrete pile caps, the piles, the soft soil that prevents buckling of the piles, and finally, the sand layer at depth with sufficient bearing capacity to carry the total load. The section on fig. 1 contains a sheet pile wall at the center line of the embankment. This structural element served the purpose of securing half the embankment for railway traffic, while the other half was being reconstructed.

The embankment was composed of medium to coarse sand, compacted to 97 % of standard Proctor density at which the angle of internal friction was about  $35^{\circ}$ . The arching effect within the piled embankment and the load distribution on the pile caps were evaluated according to Scandinavian experience (Rathmayer 1975). 70 % of the vertical dead and live load were assigned to arching, the remainder has to be carried by the geogrids in contact with the soil between the pile caps. For the design of the 3 geogrid layers, British Standard BS 8006 and publications by Jones et al. (1990) were taken into consideration. The forces in the geogrid reinforcement were analyzed with a simplified tension membrane model and alternatively with a flexural plate model. Partial factors of safety were employed for the evaluation of the limit state with respect to structural failure. With regard to the limit state of usability, the maximum permissible long term strain of the geogrids was specified at 3%. Unknown dynamic effects due to trains passing, were taken into account by a dynamic load factor. Based on the structural analyses, 3 layers of woven polyester geogrids were selected. Their short term strength in warp and weft is 150 kN/m each. Under design loading, the geogrids experience no more than 20% of their short term tensile strength. Since the tension membrane is continuous in the directions parallel and perpendicular to the railway embankment, attention had to be paid to seams and overlaps. Special tests were carried out at the Geosynthetics Laboratory of LGA for this purpose. The laboratory also supervised the quality of the manufactured geogrids.

### 3 MONITORING PROGRAM

Since there is little or almost no experience with the described geotechnical structure, and since the

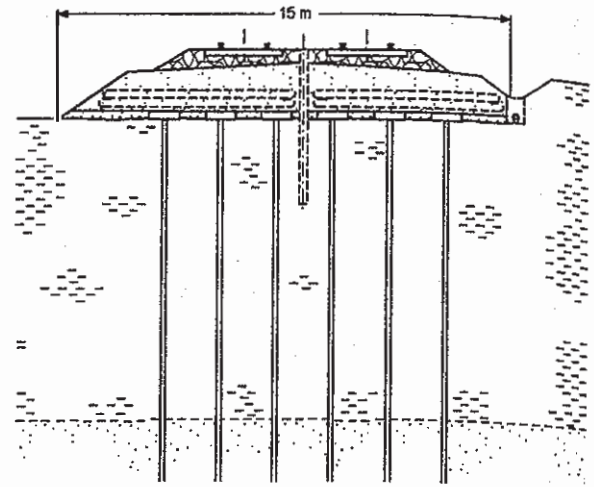

Fig. 1: Cross section of the embankment

interaction of the different components of the structure is rather complex, it would be insufficient to assess the structural safety and the serviceability on the basis of calculations only. In this case, it is mandatory, to carry out extensive measurements, in order to facilitate the comparison of predicted and observed performance.

#### 3.1 Parameters to be measured

The performance of the geogrid-reinforced earth embankment on piles can be assessed with a sufficient degree of accuracy, when the displacements and the deformations of the embankment as well as of the piles are known. Since it is only possible to execute measurements at a few characteristic points, it is necessary to select the most significant parameters for the monitoring program, taking the limitations of measurement techniques in practice into account. Under these aspects, it was decided to monitor the following parameters:

1. Settlements and horizontal displacements of the geogrid-reinforced embankment.
2. Strain of the geogrid layers between the piles and above the piles.
3. Displacements and tilt of the pile caps.
4. Strains of the piles near their tops.

It is of particular interest to distinguish between the response of the structural components to dead load caused by the weight of the embankment and to the dynamic live load when trains are passing. So, the measurement facilities were selected such, that dynamic readings could be taken with a sufficient resolution to determine the performance

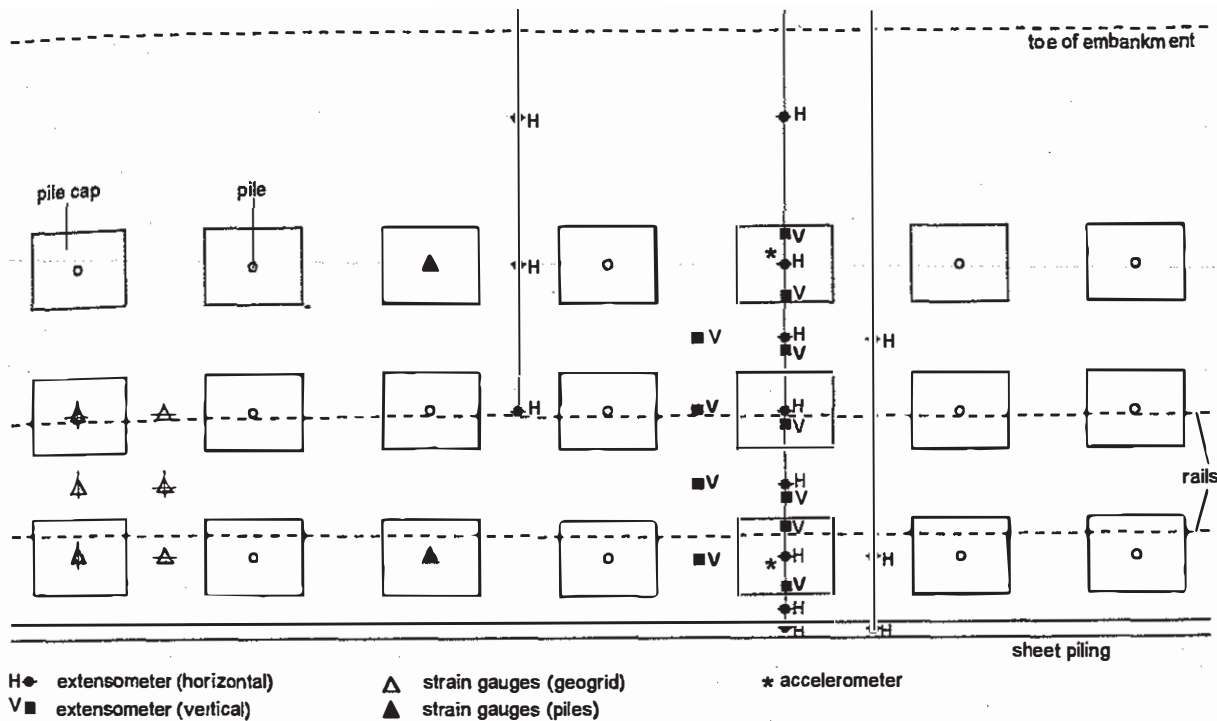

Fig. 2: Instrumentation of the monitoring section

of the structure under cyclic loading, and to recognize the influence of the train velocity. Furthermore, it is required that the monitoring system should work reliably over a longer period of time, because the anticipated accumulation effects of creep and of repeated loading should be monitored as well.

### 3.2 Instrumentation

In order to gain quantitative information about the performance of the geogrid-reinforced embankment as soon as possible, the first monitoring section was installed at the very start of construction. The instrumented section was located above a soil profile with soft strata to about 20 m depth, representative of a major portion of the reinforced embankment. At a later time, another section was instrumented in the same way. There, the ground was extremely soft with soils of low bearing capacity to a depth of about 30 m. The second complete monitoring section is representative of the smaller portion of the reinforced embankment area above very soft ground. Fig. 2 shows the first monitoring section in plan view. The total length of the instrumented section, needed to place all measuring devices and controls in such a way that the instruments do not disturb each other, amounts

to about 15 m. The following transducers were installed:

1. Electrical resistance strain gauges attached to the geogrids between the piles and above the piles.
2. Electrical resistance strain gauges attached to the surface of the piles at a short distance below the pile caps.
3. Vertical rod extensometers to monitor the settlements and the tilt of the pile caps and to measure the vertical displacements of the geogrid reinforcement layers between the pile caps.
4. Horizontal rod extensometers to detect any spreading of the embankment.
5. Accelerometers for the measurement of the vibrations below trains passing.

The geogrids are supposed to act like tension membranes. Maximum tensile forces are expected in the lowest geogrid layer between the pile caps, and in the uppermost layer above the pile caps. The strain gauges were placed accordingly. Strains are measured in directions parallel and perpendicular to the railway tracks.

The settlements of the reinforced soil cushion are measured by rod extensometers. Fig. 3 indicates that most of the extensometers monitor the vertical displacement of the lower geogrid layer. Some of them record the settlement of the upper layer as well, so the compaction of the reinforced soil cushion under traffic load can be determined. At

two locations the settlement of the ground, 0.5 m below the reinforced section, is recorded.

Applying the known stress-strain behavior of the geogrids, forces acting in the reinforcement can be deduced directly from the strain gauge readings. On the other hand, the measurements of the rod extensometers provide integral values for the vertical displacements of the soil layer, that can be used to derive deformations, which have to correspond in magnitude to the local strain measurements. So, the results of these two independent measuring techniques can be used for cross checking.

The pile caps are acting as footings for the soil arches that develop in the embankment above the gaps between the caps, and in addition, they have to carry the forces of the geogrid membranes. So the pile caps are crucial elements of the structural system. To determine the settlements and the tilts of the pile caps, the end points of extensometers were attached to the pile caps directly as shown on Fig. 3.

Four piles were selected for the determination of pile forces by means of surface strain measurements. At a distance of 0.35 m below the upper ends of the piles, where stress perturbations due to local irregularities of the contacts between pile ends and pile caps should have ceased, electrical resistance strain gauges were attached to the piles. Two piles were equipped with 4 strain-gauges each, in order to measure any bending moments in two directions. Two piles were instrumented with two strain gauges, here bending is detected in the direction perpendicular to the railway tracks only.

### *3.3 Implementation of the monitoring devices*

The first monitoring section was installed in May 1994, the second one in June 1995. The field work of the technical specialists had to be executed under extreme time pressure, because no delay in construction production was permitted. So, the field work had to be planned in great detail, and all measuring instruments had to be prepared in advance as far as possible. Fine instruments are sensitive to bad weather conditions, so precautions had to be taken in this regard. Tents were provided to facilitate the implementation of the transducers under shelter, if needed. The local conditions were sometimes quite difficult. For example, the ground water table, which was close to the ground surface, had to be lowered locally, to facilitate the

instrumenting of the strain gauges at the piles in the dry.

Great care was taken to avoid any mistakes which cannot be corrected any more after the completion of construction. The placement of transmission cables leading from the strain gauges to the recording unit required particular attention. Mechanical damage during instrumentation and subsequent construction work had to be avoided. The cables must be long enough and arranged in such a way, to allow for ground deformations at the base of the railway embankment without being cut off. All cables were collected in a shaft structure at the toe of the embankment, from where, protected by a plastic pipe, they were lead to the nearby monitoring container located at the other side of a construction road. For this purpose, protecting plastic pipes were employed. All readings are taken electrically and recorded by computer to be stored on magnetic tape or disc.

### *3.4 Execution of the measurements*

Since completion of the embankment, readings of all the instruments were taken 9 times, at monitoring section 1, and 4 times at section 2. The time interval between the first and the second reading was two weeks. Subsequently, the intervals were doubled in accordance with the leveling off of time dependent response. The displacements picked up by the rod extensometers can only be evaluated under static conditions by leveling when no trains are passing the monitoring section. The strain gauges are read by a rate of 41.5/s per channel. This rate permits the recording of individual bogies passing. The facilities for strain measurements under dynamic conditions can also be used to measure the strains under static conditions, when no trains are passing.

## 4 MEASUREMENT RESULTS

In monitoring section 1, measurements have been taken since May 1994. At the time of the preparation of this paper, data had been recorded for 18 months. Subsequently, some results of monitoring section 1 are presented and discussed briefly. The development of the measurement results of monitoring section 2 is very similar, but due to the construction sequence there, the time of observation is shorter.

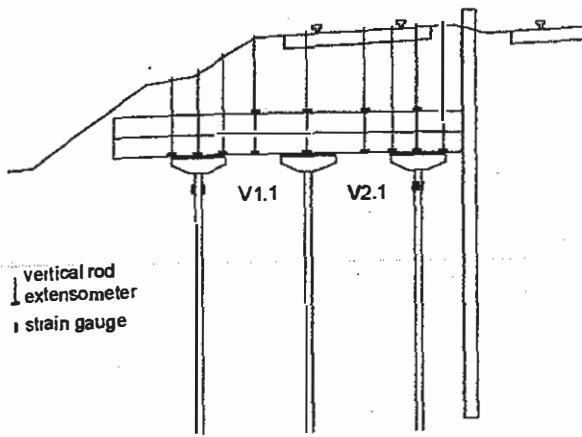

Fig. 3: Vertical rod extensometers

#### 4.1 Settlements

The rod extensometers sketched on fig. 3 permit the measurement of vertical displacements at certain points under static conditions. Plotted to a distorted scale, fig. 4 indicates the tilt of the pile caps and the catenary shape of the deformed geogrid. The only measured points of these curves are the maximum settlements at the midpoints between the pile caps and the edges of the pile caps, the curves as such are estimated. It is evident, that the geogrid is exposed to the maximum loading below the railway tracks and accordingly, the maximum sag of the reinforcing membrane of the order of 40 mm occurs between the pile caps immediately below the tracks. Since the cap of the middle row of piles is equipped with one extensometer only, it is not known whether this cap is tilting like the other two. The direction and magnitude of rotation of the pile caps may depend upon the forces applied by the geogrids, but due to the limited number of instrumented locations, there is not sufficient evidence to prove this assumption. It is also possible that the deviation from the horizontal direction is caused by imperfect placement during construction.

The settlements of the pile caps are on the order of 10 mm. A comparison of the settlements of the upper and the lower geogrid layer reveals a difference of about 25 mm. This means, that the reinforced soil cushion which had a thickness of 0,45 m at the end of construction, experienced a considerable compaction under the dynamic impact of passing trains.

The vertical displacements plotted on fig. 4 refer to the measurements taken in November 1995. The development of the settlements with time is shown

on fig. 5. Curves V2.1 and V1.1 correspond to measurement points between the pile caps as indicated on figs. 3 and 4, the upper two lines show the settlements of the pile caps. Evidently, the vertical displacements are increasing with time, that means with the number of trains passing the monitoring section. As trains were running at reduced speed during the construction period, long term predictions cannot yet be made on the basis of the presented curves. Since December 1995, trains are operating at full speed, so after a few more readings, it should be possible to evaluate the long term performance. Most recent measurements indicate, that the rate of vertical displacements is becoming very small.

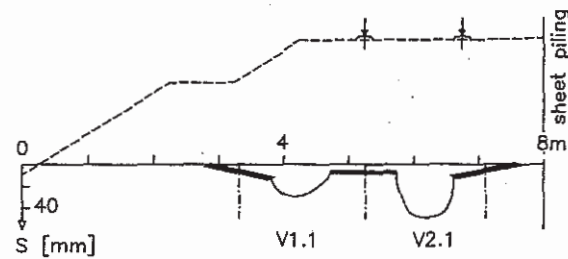

Fig. 4: Vertical displacements

#### 4.2 Geogrid strain measurements

The measured strains under static conditions are on the order of 0.3 to 1.0 %, the larger values being observed at the lower geogrid layer in the center between four pile caps. These values compare well with the deformations deduced from extensometer recordings. Like the settlements, the measured strains are increasing with time, that means with the number of trains. But as can be seen on fig. 6, the time dependent increase of strains is smaller than the time dependent increase of total vertical displacements. So, the internal composite structure formed by the soil and the geogrid reinforcement appears to have reached a stable condition, while the interaction of the entire structure with the ground is still in a transient state. This impression is supported by the pile strain measurements as well, which are not presented in the present paper. Based on the observations, it seems justified to predict that in the long term, the strains of the geogrid reinforcement will not reach the limit value of 3 % specified for the design with respect to the usability of the reinforced embankment.

Apart from the described static conditions, strains

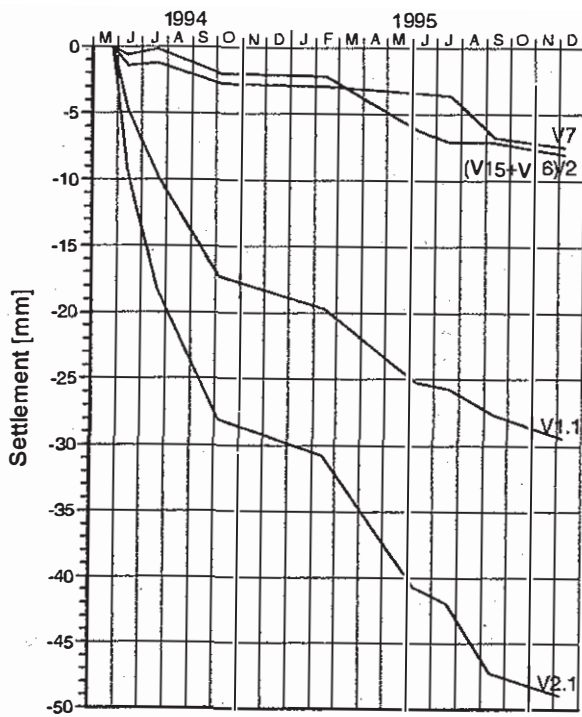

Fig. 5: Settlements with time

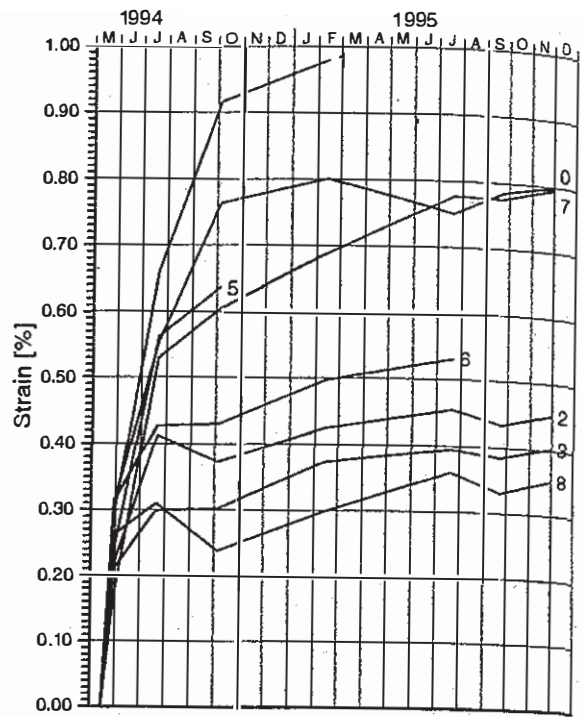

Fig. 6: Static geogrid strains with time

are also measured, when trains are passing the monitoring section. Fig. 7 represents a typical recording of geogrid strains perpendicular to the axis of the railway embankment when a train is passing. The strain difference between the static state of the geogrid under dead load and the geogrid under static plus dynamic traffic loading amounts to 140  $\mu\text{m}/\text{m}$  only. This clearly indicates that the reinforced embankment acts as a composite structure which is in a kind of prestressed condition.

The dynamic strain measurements depict each boggy of the train. It is even possible to identify heavier or lighter wagons, such as the dining car in the middle of the Intercity Express. The strain measurements are so sensitive that a slight decrease of tensile strain in longitudinal direction of the geogrid is noticed when the train approaches the monitoring section.

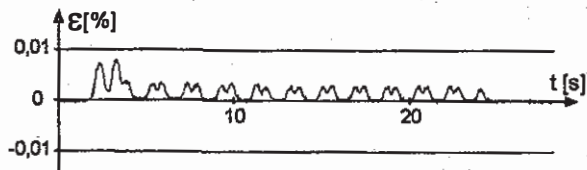

Fig. 7: Dynamic geogrid strains

## 5 CONCLUSIONS

For a geogrid reinforced railway embankment founded on piles, a monitoring program was developed and implemented. Since almost two years, the instrumentation has performed very well and yielded reliable data for the evaluation of the performance of the geogrid reinforced structure. The measurements indicate that the structure responds to the dead and live loads in a satisfactory manner, and that a sufficient margin of safety with respect to stability as well as adequate serviceability can be assigned to the geogrid reinforced embankment.

## REFERENCES

- British Standard Institution 1994. BS 8006. Code of practice for strengthened/reinforced soils and other fills.
- Jones, C.J.P.F. & Lawson, C.R. & Ayres, D.J. 1990. Geotextiles reinforced piled embankments. *4th Int. Conf. on Geotextiles, Geomembranes and Related Products, Den Haag, Vol. 1: 155-160.*
- Rathmayer, H. 1975. Piled embankment supported by single pile caps. *ISSMFE Conference, Istanbul, Vol. 1: 283-290.*